

GENERAL FEATURES

- Top mount
- 20 (1mm) gauge stainless steel
- Buffed satin finish
- 8" (203mm) depth
- Overall size: 25" (635mm) x 22" (559mm)
- Faucet holes: (4) 1-1/2" diameter
- 3-1/2" (89mm) center drain opening
- Cutout dimension for top mount installation: 24-3/8" (619mm) x 21-3/8" (543mm) with 1-1/2" (38mm) radius corners
- Mounting hardware for countertops up to 3/4" (19mm) thick included
- Sound insulation – spray undercoating on bottom
- Minimum cabinet size: 30" (762mm)
- Limited lifetime warranty
- This sink complies with ASMEA112.19.3-2008 / CSA B45.4-08

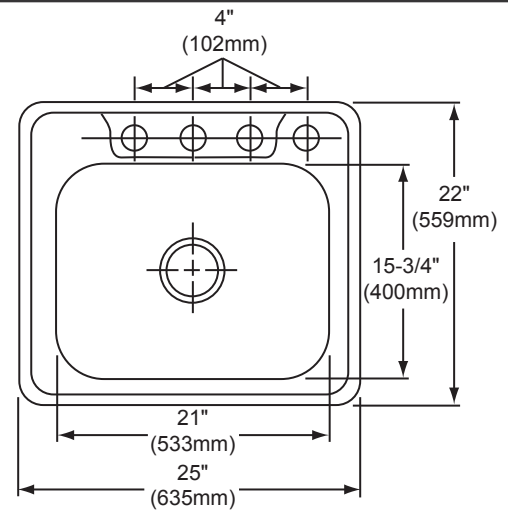

RECOMMENDED ACCESSORIES

Bottom Grid: LKWBG2115SS, GBG2115SS

Cutting Board: CB1516

Drain: D1125, LK35

Faucet Hole Cover: LK125R



In keeping with our policy of continuing product improvement, Elkay reserves the right to change product specifications without notice. Please visit elkayusa.com for most current version of Elkay product specification sheets.

This specification describes an Elkay product with design, quality and functional benefits to the user. When making a comparison of other producers' offerings, be certain these features are not overlooked.