

ACE

SPECIFICATIONS

Model AE33224
ACE #43033

GENERAL FEATURES

- Top mount
- 23 gauge stainless steel
- Satin finish
- 6" depth
- Overall size: 33" x 22"
- 3-1/2" center drain opening
- Faucet holes (4) 1-1/2" diameter
- Cutout dimension: 32-3/8" x 21-3/8" with 1-1/2" radius corners
- Mounting hardware for countertops up to 3/4" thick
- Sound insulation – sound absorbing pads
- Minimum cabinet size: 36"
- 3 year limited warranty
- Complies with ASME A112.19.3-2008/CSA B45.4-08

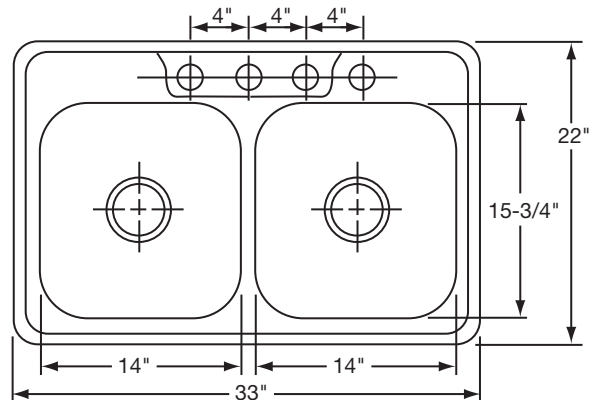

RECOMMENDED ACCESSORIES

Drains: D1125, LK35, LK99

ALL DIMENSIONS IN INCHES, TO CONVERT TO MILLIMETERS MULTIPLY BY 25.4.

In keeping with our policy of continuing product improvement, Elkay reserves the right to change product specifications without notice. Please visit elkayusa.com for most current version of Elkay product specification sheets.

This specification describes an Elkay product with design, quality and functional benefits to the user. When making a comparison of other producers' offerings, be certain these features are not overlooked.